

CART CHAMBERS

Quaternary Chemical Cart Disinfection

Features:

- Industry established cart disinfection system
- Stainless steel /insulated dual wall construction
- Built-in mechanical chamber
- HMI touchscreen control and diagnostics
- Fully adjustable cycle times
- Pass-through entry/exit doors
- PLC based, UL listed controls and components
- Over-pit drain configuration (standard)
- Easily accessible service components
- Less than 1 gallon water per cart (standard)

Benefits:

- Effective against bacteria and viruses
- Up to 30 carts per hour productivity rate
- Accommodates all cart types
- Suitable for all chemical disinfectants
- Requires no daily adjustments
- Supports industry healthcare accreditations

Added Options:

- Pre-wash cycle with additional pump and spray assembly
- Automated entry/exit doors
- Automated end-of-cycle cart ejection
- Built-in sump with ramps (for level floor installations)
- Forced air drying assist

DISINFECTION CHAMBERS



Quaternary Chamber (w/ sump, ramp, and blower)

Utilities:

- Water
 - Supply: 10 GPM @ 35 PSI, Connection: 3/8"
 - Temperature - Max 140° (high temp. package option available)
- Compressed Air
 - Supply: 1/2" NPT, 2 CFM @ 80 PSI, Connection: 1/4"
 - Filtered and Dried
 - Doors: 40 psi; Cart ejection: 80 psi
- Electrical
 - 240/60/3 40 FLA, or
 - 480/60/3 20 FLA

Disinfection:

- Requires purchased chemicals
- Dwell time -in minutes (varies per chemical manufacture guidelines)



CART CHAMBERS

Chamber Dimensions:

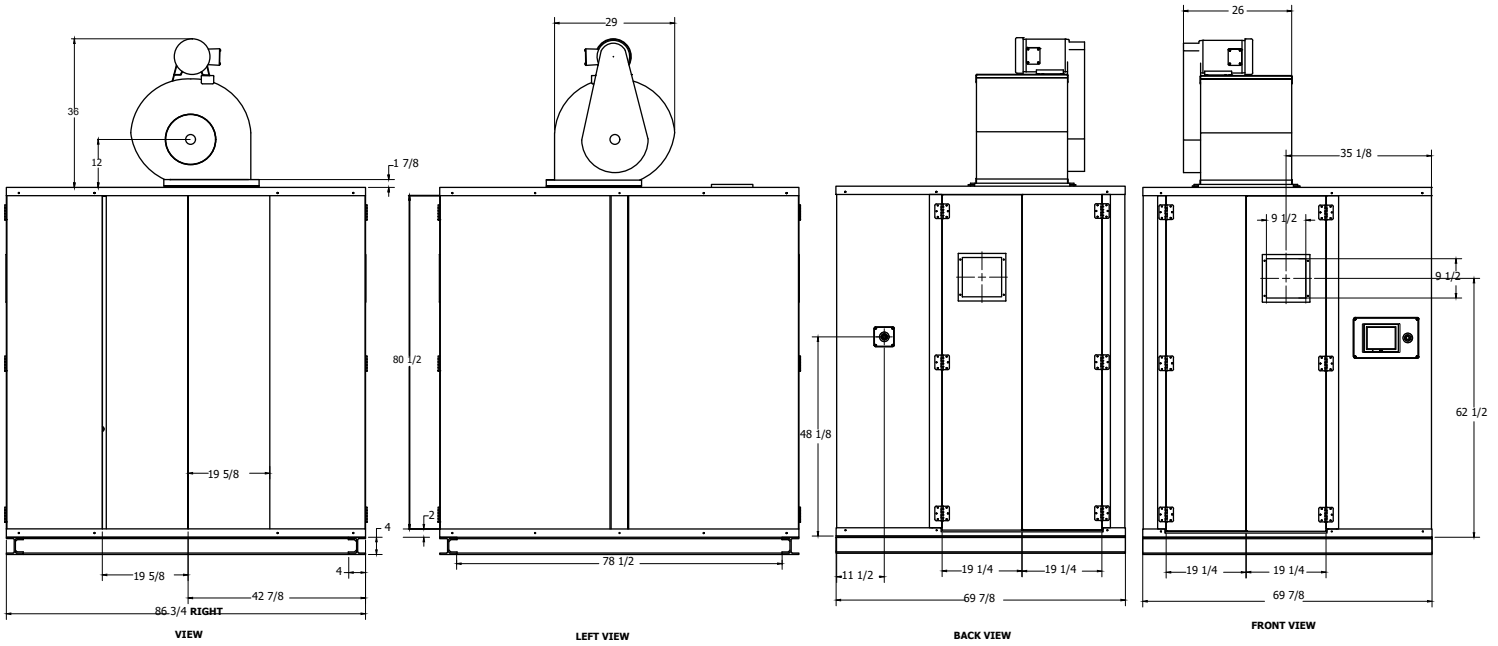
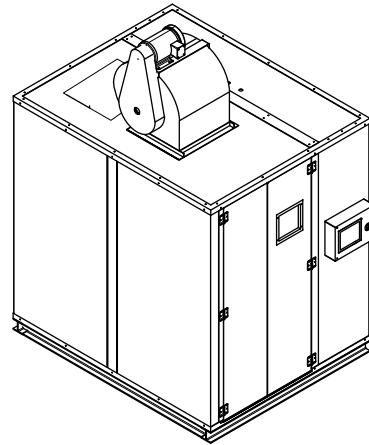
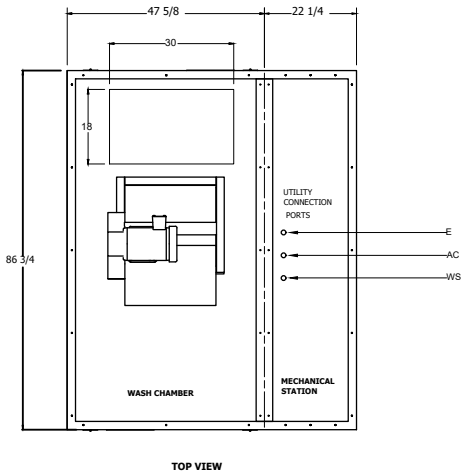

Fully Assembled & Factory Tested

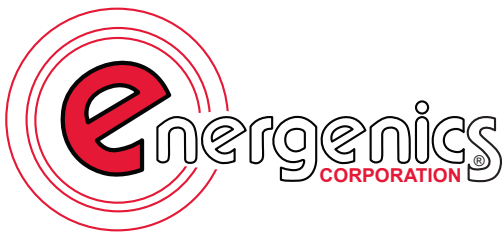

**Ask About Our UV-C
Chambers and Retrofit Kits!**

www.energenics.com