

KARTWASHER

**Installation and Operation Manual
HOCL (SCHNEIDER) ELA-400ANW**

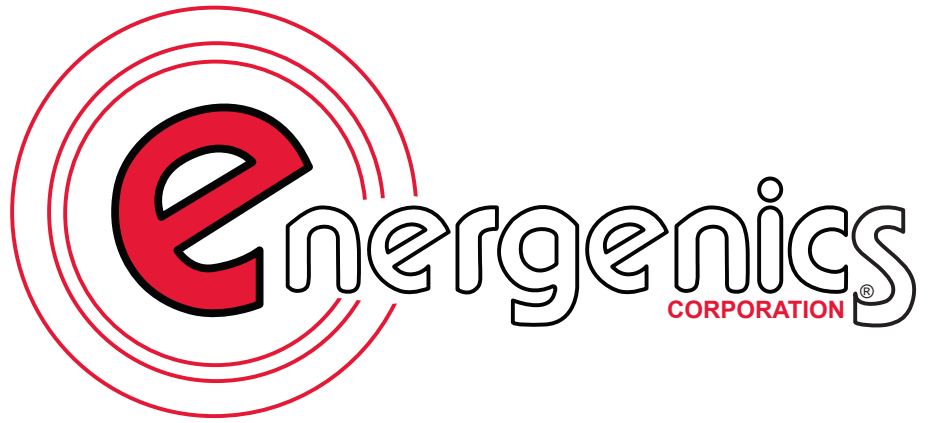

**ADVANCED DISINFECTION
TECHNOLOGY**

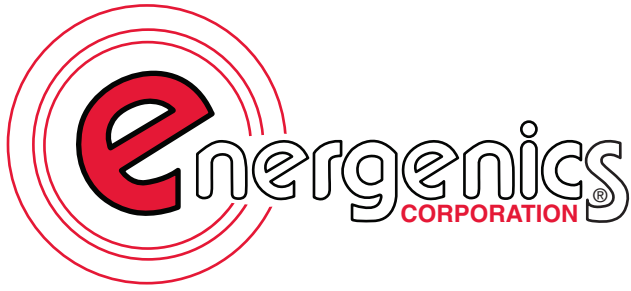

1470 Don Street
Naples, FL 34104
(800) 944.1711
www.energenics.com

PART 1:

**INSTALLATION & UTILITY CONNECTION REQUIREMENTS
HYPOCHLOROUS ACID (HOCL) KARTWASHER**

PART 2:

**SCHNEIDER DISPLAY - HOCL KARTWASHER
OPERATING AND PROGRAMMING INSTRUCTIONS**

PART 3:

**OPERATION AND MAINTENANCE MANUAL FOR
ELA-ANW SERIES HOCL GENERATORS**

PART 1

1470 Don Street • Naples, Florida 34104

Customer Service: (800) 944-1711
Fax: (239) 643-6081

INSTALLATION & UTILITY CONNECTION REQUIREMENTS HYPOCHLOROUS ACID (HOCL) KARTWASHER

TABLE OF CONTENTS

RIGGING THE KARTWASHER

Kartwasher Unloading	4
Floor Installation	4
Pit Installation	5
Kartwasher Overall Dimensions	6
Standard 4-inch Beam Pit Dimensions	7
Built-in Sump	8
Yellow Exit Pole Sensor Placement	9

UTILITY REQUIREMENTS

Salt and Solution Purity Requirements	10
Mechanical Chamber Layout	11
Water Supply (CRITICAL)	12
Compressed Air Supply	13
Electrical Supply (HOCL Generator)	14
Electrical Supply (Control Panel)	15
Enviolyte Valve Positions	16
Chemical Testing Recommendations	17

KARTWASHER UNLOADING & INSTALLATION

Your Kartwasher is shipped fully assembled and ready for your predetermined floor or pit placement. **Follow these directions:**

DO NOT SIGN BILL OF LADING UNTIL INSPECTED

1. Unwrap Kartwasher and inspect for damage during shipping.
2. The Kartwasher should be picked up with a forklift using long forks (60" minimum). If this type of forklift is not available, the Kartwasher should be carefully removed from the truck by other means. **Use caution not to damage fiberglass base beams.**
3. Lift the Kartwasher to unbolt the wood securing it to the shipping pallet. Remove the pallet and any plywood under the Kartwasher.
4. Slowly lower the Kartwasher onto the floor.

Floor Installation

1. Ensure Kartwasher is facing desired direction. Slide Kartwasher into final position (use wood between the Kartwasher frame and forks for added protection).
2. Mount to the floor in 4-8 places using appropriate fasteners per floor type.
3. Install 2 (supplied) yellow exit posts approximately 4" past the trailing edge of each door on the discharge side of the Kartwasher.
4. **Mount sensors on yellow exit post side closest to the Kartwasher to avoid damage from discharged carts.** Installed sensors will ensure the cart is completely clear of the doors before beginning a new cycle. (See Page 6)

5. Mount entrance and exit ramps on models with built in sump option. Ensure exit ramp is flush to the floor level for smooth exit of carts.

Pit Installation

1. Ensure the Kartwasher is facing desired direction. Remove the shipping blocks.
2. Employ appropriate rigging techniques and personnel to carefully lower the Kartwasher into the prepared pit. (See Page 5)
3. Install (2) yellow exit posts (supplied) approximately 4" past the trailing edge of each door on the discharge side of the Kartwasher.
4. **On side closest to the Kartwasher (to avoid damage from discharged carts), mount photo-eye sensors on yellow exit posts.** Sensor installation is required to ensure a cart has completely cleared the exit doors before unit will beginning a new cycle. (See Page 6)

KARTWASHER OVERALL DIMENSIONS

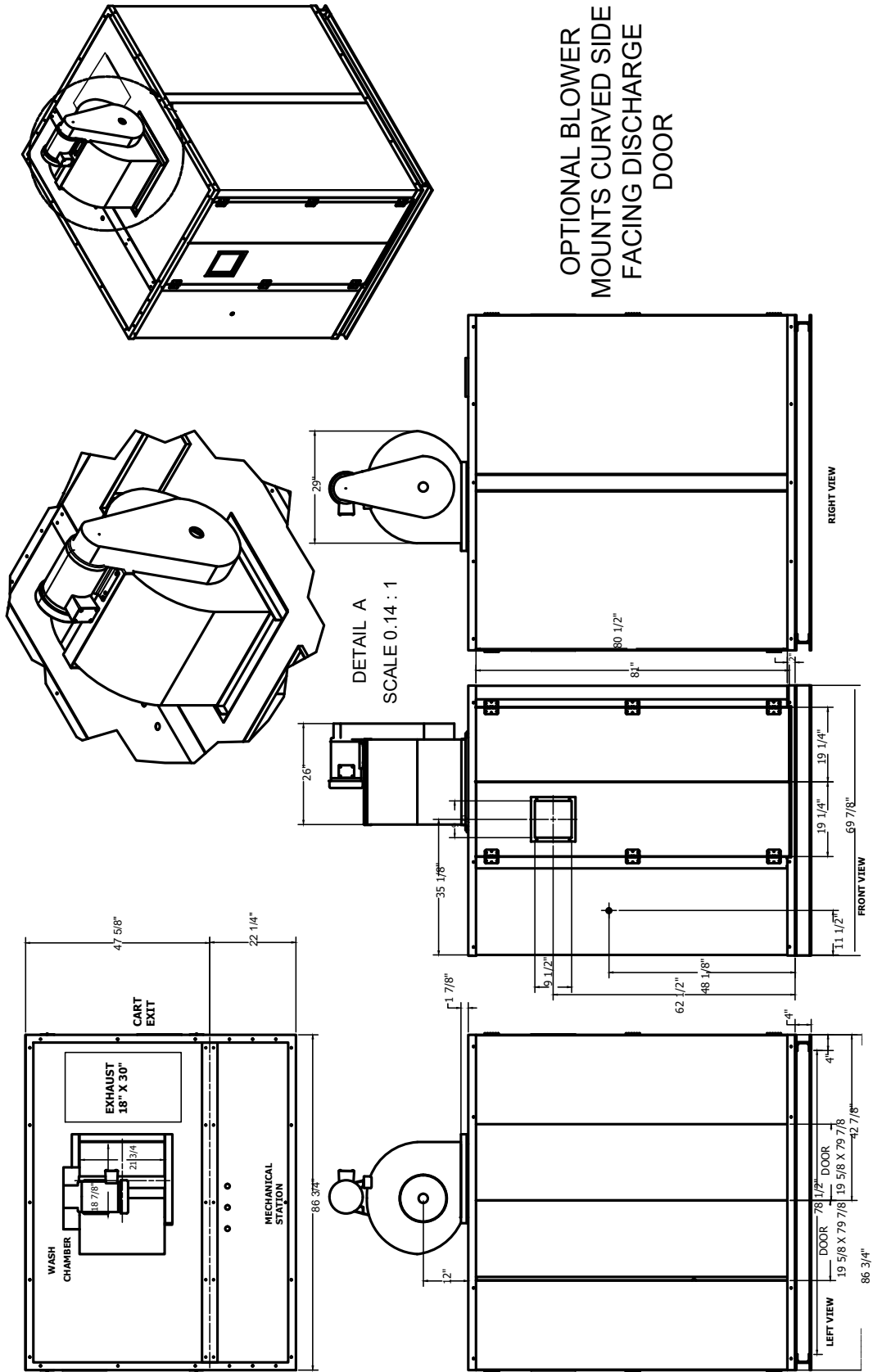

OPTIONAL BLOWER
MOUNTS CURVED SIDE
FACING DISCHARGE
DOOR

DETAIL A
SCALE 0.14 : 1

4-INCH BEAM PIT DIMENSIONS

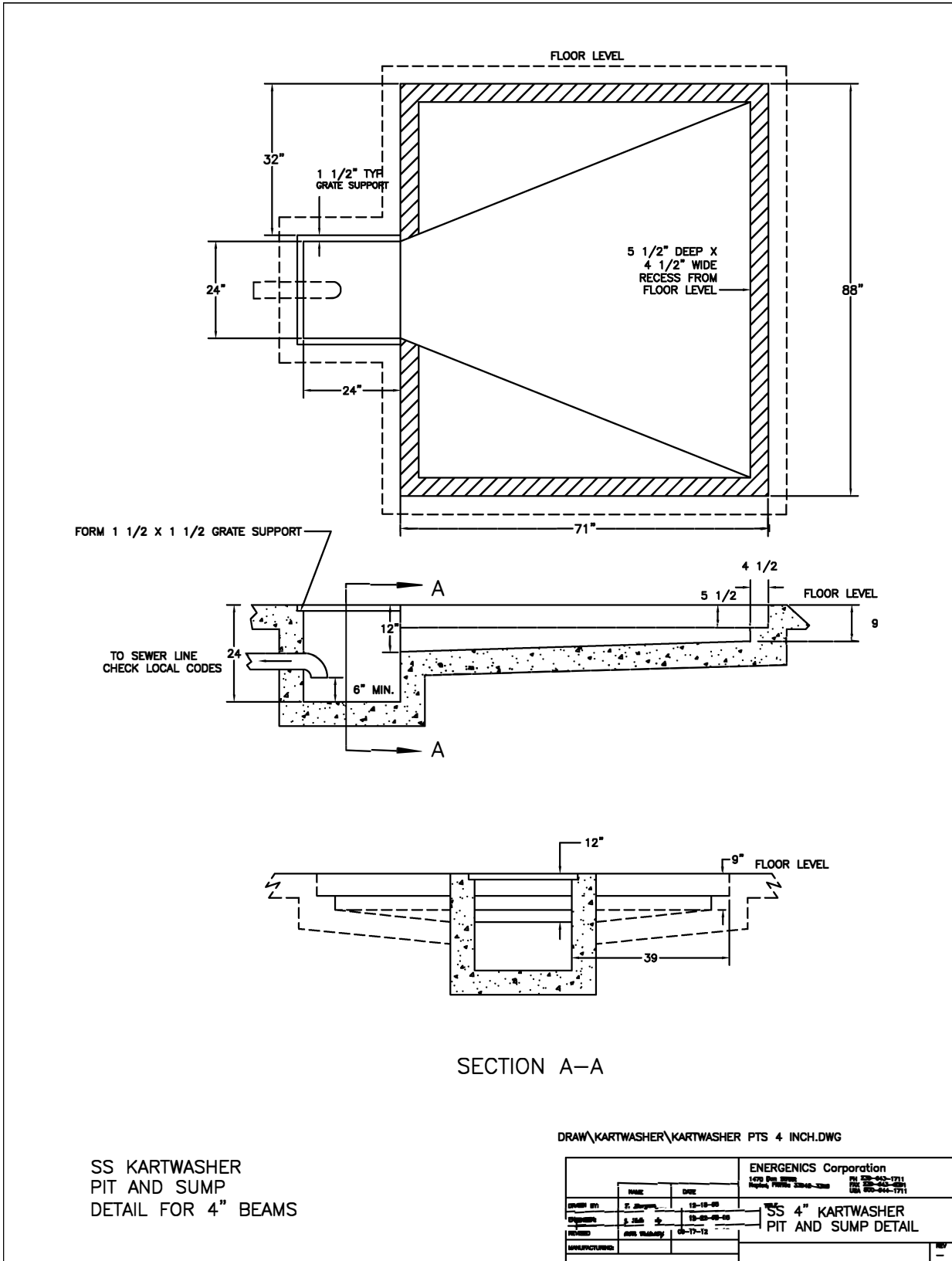

***This configuration allows carts to be loaded / unloaded at floor level. The unit is permanently installed and not easily moved.**

BUILT-IN SUMP WITH LOADING / UNLOADING RAMPS

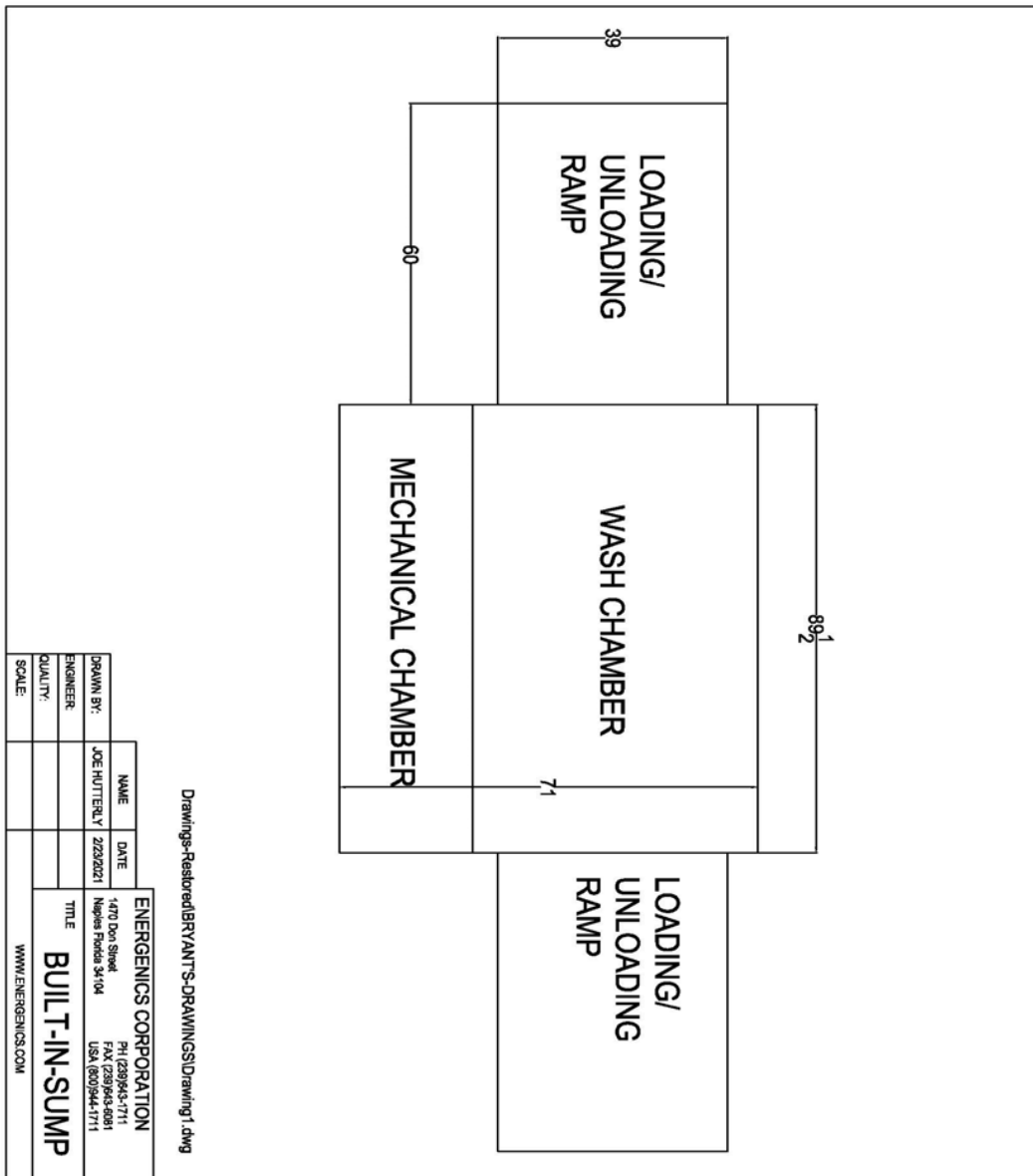

***This configuration allows the Kartwasher to be placed on the surface of a finished floor. A 1-inch piece of PVC coupling is installed under each loading / unloading ramp (required) for draining. Use one end for draining and cap the opposite side. The built-in sump allows for relocation of the unit for future growth.**

EXIT POST AND SENSOR PLACEMENT

1. Position exit posts (supplied) approximately 4-inches past the trailing edge of the open exit door edge.
2. Posts must be installed equidistant from exit door edge so that photo-eye sensors are equally positioned.
3. Mount photo-eye sensors on the side of post nearest the Kartwasher to avoid exiting cart damage.
4. Secure post positioning with appropriate fasteners.

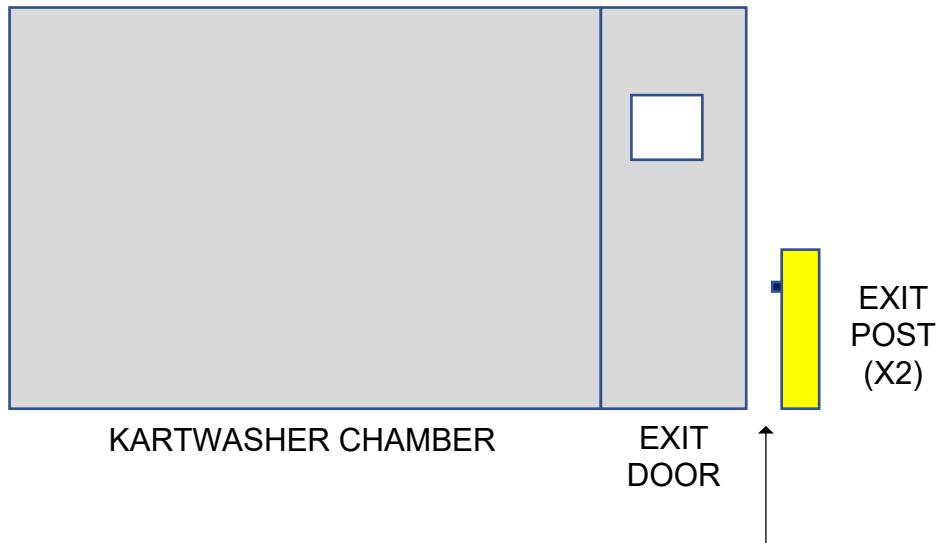

- POST APPROX. 4" FROM DOOR
- SENSOR ON DOOR SIDE OF POST
- POST AND SENSOR PLACEMENT IDENTICAL EACH SIDE

SALT PURITY REQUIREMENTS

1. **To ensure optimal performance, the salt used must be >99% pure and not contain additives.** Swimming pool and spa grade salt is recommended.

*Using lesser quality salt may cause rapid plugging of the diaphragm.

*Using salts with a substantial amount of other cations (e.g. magnesium or calcium) will result in extra cleansing and a reduced lifetime of the membrane.

SOLUTION PURITY REQUIREMENTS

Ideal conditions for solution production:

Salt: >99% purity NaCl

Water: electrical conductivity, (EC) <30 $\mu\text{S}/\text{cm}$ @ 20°C (68°F) (pH 5.0-8.0) temp <20°C (68°F)

UTILITY REQUIREMENTS

Failure to comply with utility requirements may result in:

- Damage to the machine
- Incurred travel expenses of factory technician(s)
- Voided warranty

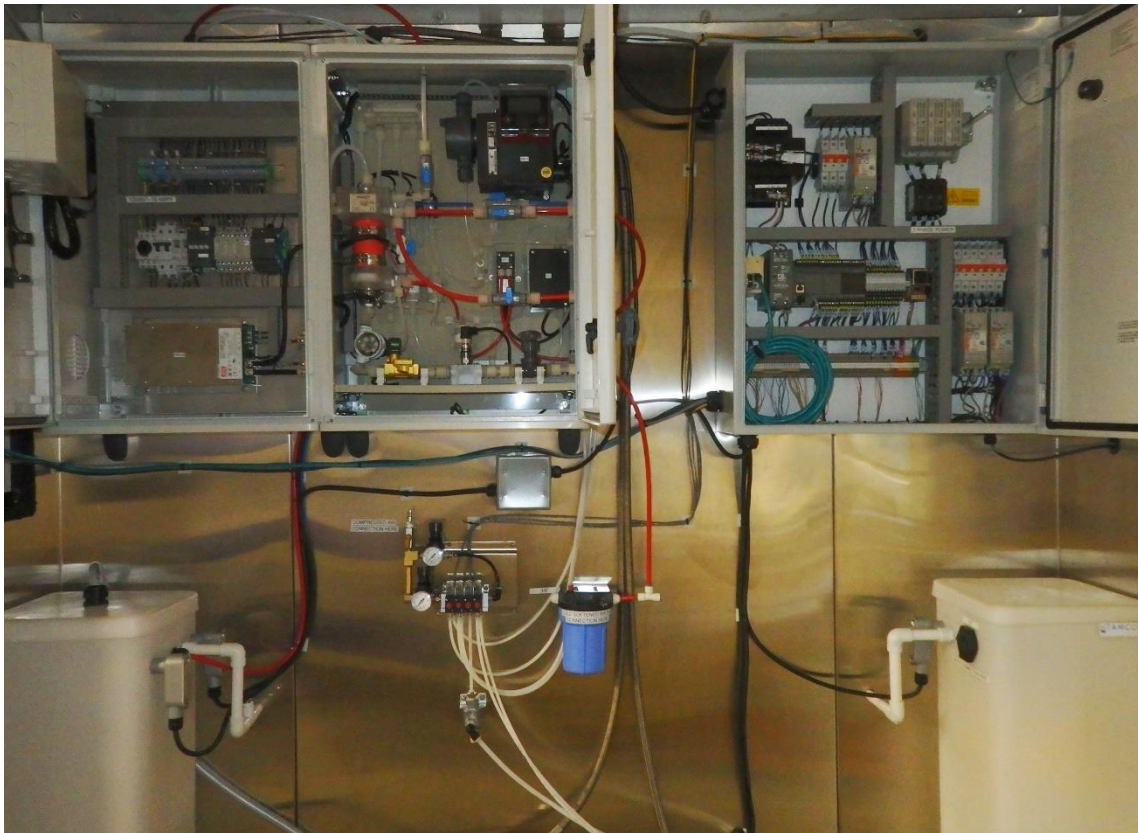

WATER SUPPLY REQUIREMENTS

1. The HOCL Kartwasher requires a 3/4" fresh, cold, and softened water supply line.
2. Connect a dedicated softened supply line (less than 50mg/L or 3.5 grains/gal of calcium carbonate) to the provided filter (blue).

***Water hardness greater than the above stated levels will result in premature wear to internal components, additional maintenance, shortened service life, and produce a corrosive chemical solution.**

3. Water Pressure must be consistent; no lower than 15 psi and no greater than 35 psi.

***Water pressure below 15 psi will result in the System Alarm "LOW WATER PRESSURE/FLOW" on the Enviolyte unit display. Water pressure above 35 psi will result in the System Alarm "BIG FLOW." The machine will not operate in an Alarm State (alarm states will automatically reset in the event of anomalous fluctuations).**

4. Water temperature should be 68°F (20°C).

***Enviolyte factory solution purity requirements call for a 68°F water supply. Under no circumstances should the water supply exceed 85°F.**

***Water supply over 90°F will result in a System Alert visible to the operator (machine will continue to operate) indicating "OVER TEMPERATURE WATER" and will greatly reduce lifetime of the electrolysis cell.**

COMPRESSED AIR SUPPLY REQUIREMENTS

1. The HOCL Kartwasher requires a 1/2" compressed air supply line.
2. Connect filtered, dried compressed air with a constant pressure no lower than 80 psi and no higher than 100 psi.

*If supplied air pressure is below 80 psi, the cart floor will not properly lift to eject the cart. If air pressure is above 100 psi, premature failure of the solenoid valves will occur. These are not covered under the standard warranty.



Regulated Pressures:

Upper (80 psi) - Ejector Bags and Stop Pin

Lower (20 psi) - Doors

ELECTRICAL SUPPLY REQUIREMENTS (ENVIROLYTE GENERATOR)

1. Connect dedicated 120/60/1 wiring from building power source. Ampere requirement is 15 amp.

***Do not power the HOCL generator system with power obtained from the Kartwasher control panel. The generator will draw excessive amps resulting in blown fuses.**

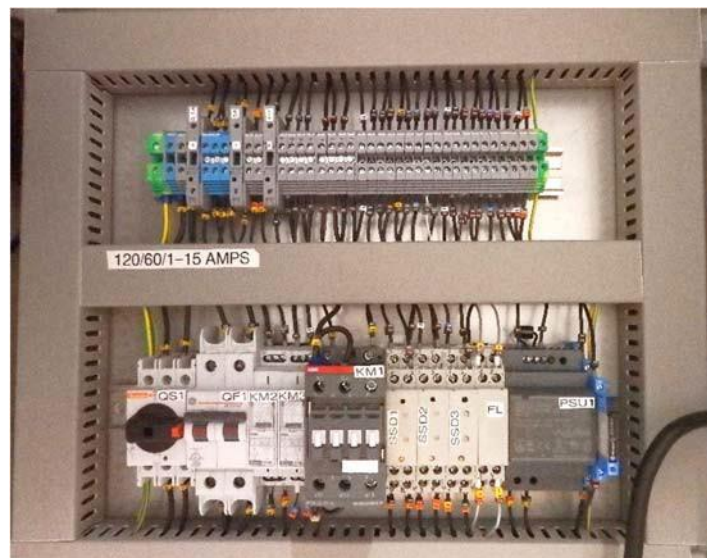

120/60/1 15 amp

ELECTRICAL SUPPLY REQUIREMENTS (KARTWASHER CONTROL PANEL)

1. Connect dedicated 240/60/3 (23.4 FLA) or 480/60/3 (11.7 FLA) wiring from building power source.

***Breaker size to be determined by local electrical codes and installers.**

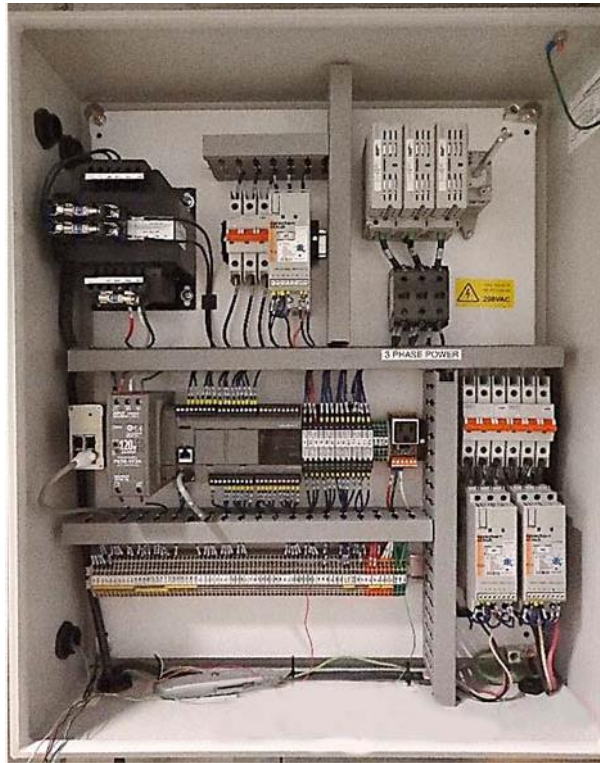

240/60/3 23.4 FLA

480/60/3 11.7 FLA

ENVIROLYTE VALVE POSITIONS

Default valve positions for normal operations are as follows:

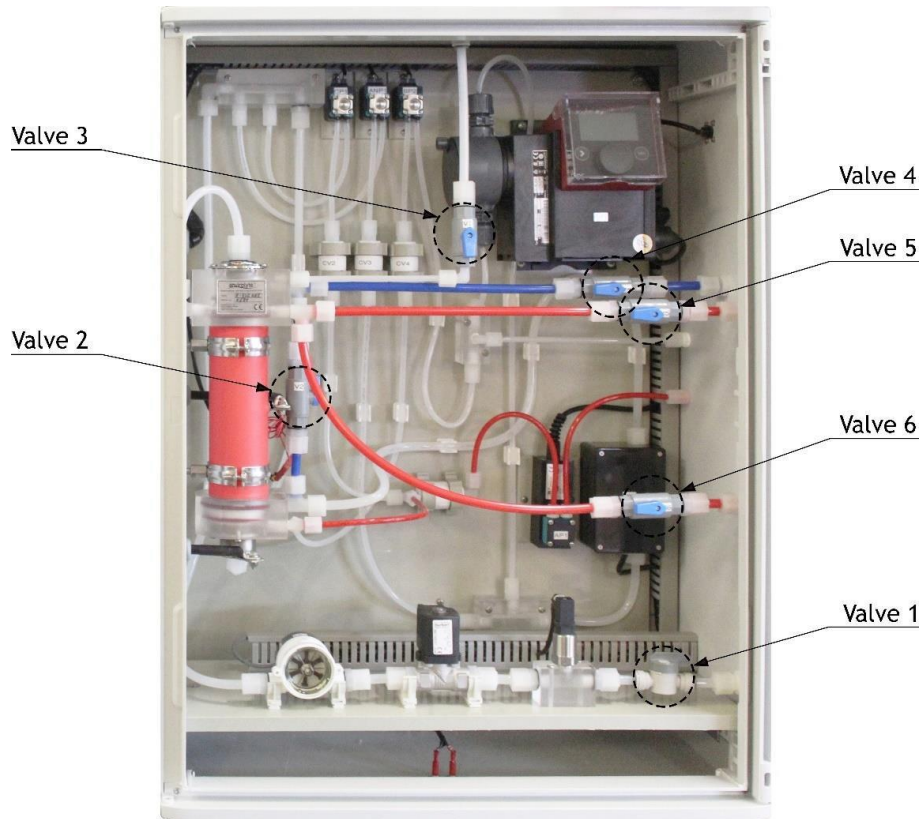

Valve	Operation Mode	Flushing Mode
V1	Constant Flow Valve	Constant Flow Valve
V2	Closed	Open
V3	Semi-Closed (H2 Vent)	Closed
V4	Open	Closed
V5	Open	Closed
V6	Closed	Open

CHEMICAL TESTING

Regular testing of newly generated solution using acceptable Free Chlorine PPM and pH test strips should be performed. Testing is done using solution contained within the chemical holding tank and not the brine tank. Below are examples of test strips with acceptable parameters:



Free Chlorine PPM Test Strips
Range: 0 - 1,000 PPM
(Should Match Device Setting)

pH Test Strips
Range: 0.0 - 14.0
(7.1 Neutral)

Note: Hard water will cause excessively high pH levels leading to corrosion and scaling.

INSTALLATION IS NOW COMPLETE

**TO OPERATE AND TO SELECT OR
CHANGE CYCLE SETTINGS, REFER TO
ENERGENICS KARTWASHER
OPERATION MANUAL (PART 2)**