

AFO-10

AirFlow Optimizer Fan Package

Features:

- Variable frequency drive (VFD)
- Pressure transducer
- Tubeaxial booster fan & motor

Benefits:

- Maintains optimal airflow minimizing dry time
- Corrects dryer inefficiencies / conserves energy
- Fully automated (after setup)

Utility Requirements:

- 208v or 480v (specify); 60 Hz; 3-phase
- Independent electrical source required

Fan Specifications:

- Drive: Belt
- Motor: 3hp; 1,740 rpm
- Max BHP: 2.91
- Fan RPM: 1,320
- Sones @ 0.250-in. SP @ 5' - 52
- Motor enclosure: enclosed / fan cooled
- Motor height: 10-inch
- Shaft diameter: 1-3/16-inch
- Blades: 6; aluminum
- FLA: 8.7-7.8/3.9
- Max inlet temp: 200 deg F
- Max ambient temp: 104 deg F
- Bearing: ball
- Mounting: vertical/horizontal
- Housing: steel; baked enamel finish

CFM

- @ 0.000-in. SP - 14,040
- @ 0.125-in. SP - 13,630
- @ 0.250-in. SP - 13,180
- @ 0.500-in. SP - 12,220
- @ 0.750-in. SP - 11,105
- @ 1.000-in. SP - 9,740



AFO - SERIES



Variable Frequency Drive, Fan, & Transducer

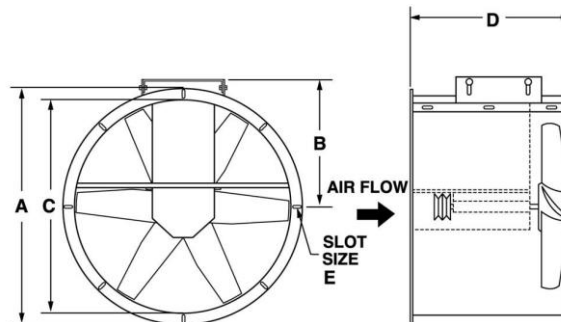

Dimensions

- A: 33-5/8"
- B: 19-1/4"
- C: 30-1/2"
- D: 24"
- E: 7/16"

INLINE SPACE SAVER TYPICAL INSTALLATION WITH AIRFLOW OPTIMIZER OR BOOSTER FAN

