

AALF LS-3000

AMBIENT AIR LINT FILTER

➔ Effectively removes lint, dust, heat, and other contaminants from the air and away from equipment, controls, and personnel

➔ Compact size makes adaptable to many settings: mounted, mobile, or floor stand options

➔ Can be fitted with ultraviolet lamps (UV-C) for room air disinfection

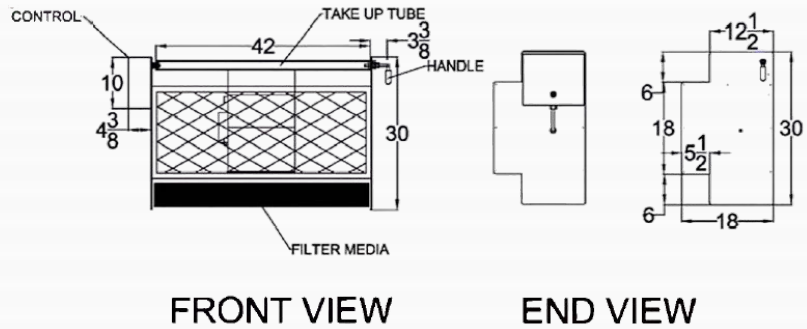

Technical:

1 x 18" w x 36" h 110 lbs
 Common 120v/60Hz/1 11.6 FLA
 Other voltages available

Applications:

- OP a n ries
- Te ile processing facilities
- Clean / pack rooms
- Corrections laundries

Standard Features:

- Ultra rugged, industrial grade build
- Antimicrobial white powder-coated frame
- 3/4 Horse-power blower motor
- 4" Non-marking locking rubber wheels (mobile)
- Easy to operate controls
- Tamper-proof hardware assembly

Construction:

- Lightweight aluminum antimicrobial powder-coated frame
- Solid state UL controls (for filter advancement)
- Arrives completely assembled (plug and play)

UV-C option:

- (8) Low-pressure, high-output, shatterproof germicidal lamps
- 254 nm treatment dose
- 12,000 hour lamp life runtime
- L ballast indicators

Approvals:

-
-

Included:

- AALF LS-3000 "Lint Scrubber"
- (2) Media filter rolls (month supply)
- 2-Year warranty



800-944-1711



sales@energenics.com | energenics.com

